



ChargePoint®

ChargePoint® EXCEL

High containment valves for cleaner, safer,
powder handling



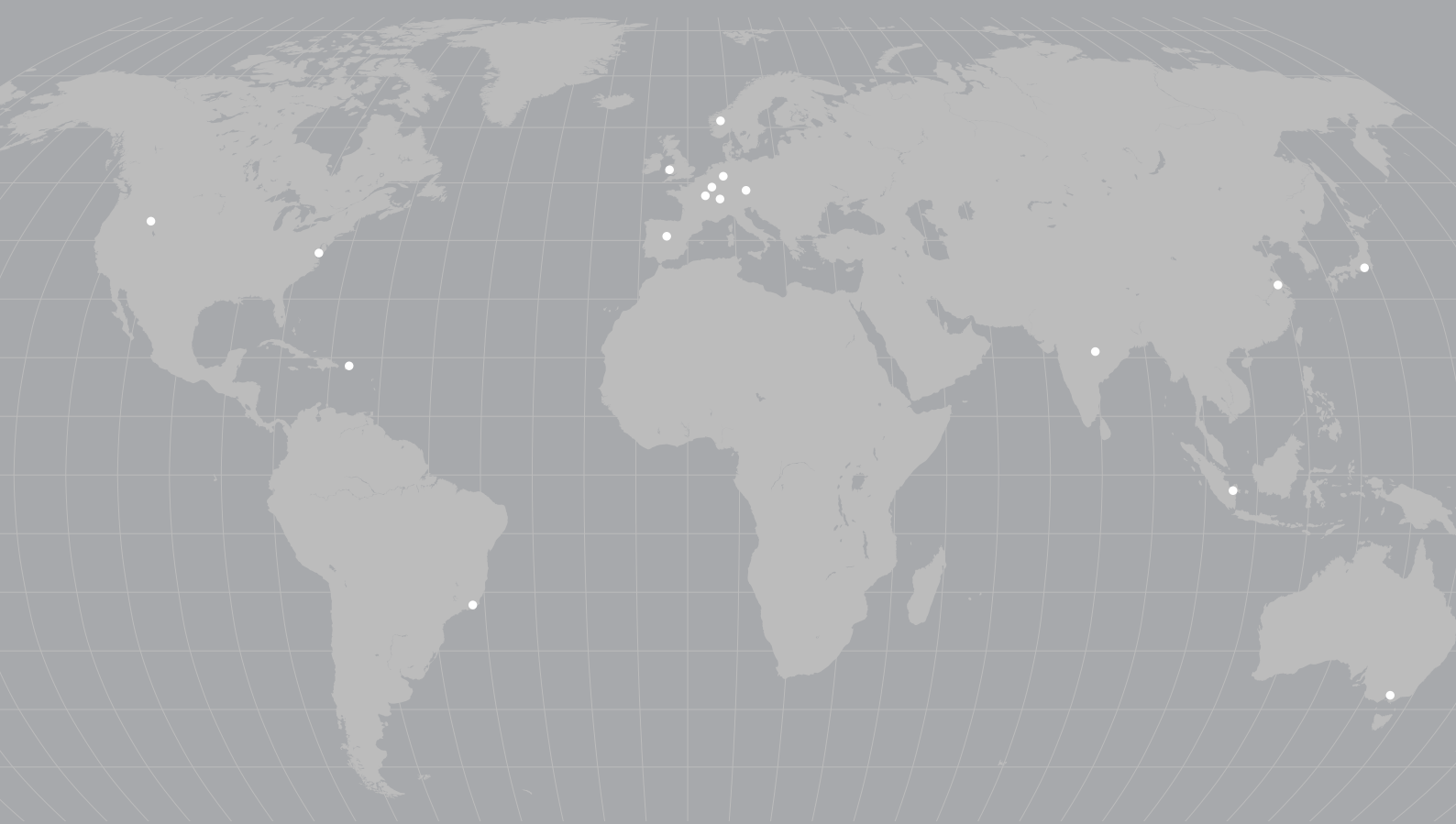

ChargePoint® Technology are market leaders in the supply of containment valves and integrated material handling equipment for the Pharmaceutical, Chemical, Food and other process based industries.

Our most important goals are to create lasting partnerships by providing high quality and reliable products, coupled with outstanding customer service.

As a pioneer of split valve technology our consultative approach will provide the right technological solution, as well as delivering the lowest cost of ownership benefits by maximising yield, reliability, productivity and flexibility.

Contents

The ChargePoint® Advantage	4
ChargePoint® Simple contained powder transfers to <math><10\text{mcg}/\text{m}^3</math>, with a unique option for transfer under pressure or vacuum conditions	6
Extraction Ring System Economic extraction system for containment performance to <math><1\text{mcg}/\text{m}^3</math>	8
ChargePoint® EXCEL Advanced level of containment performance to low Nanogram levels	8
ChargePoint® DL DiscLock™ technology for fast and secure bulk transfers with containment performance of 1-10mcg/m ³	9
Cleaning and Washing in Place	10
Solutions for Clean Processing	11
Options and Accessories	12
ChargeBag™	14
ChargeBottle™	14
Specifications	15



The ChargePoint® Advantage

The ChargePoint® range of containment valves are designed to help you improve on the three key elements of Overall Equipment Effectiveness (OEE).

- Availability
- Performance
- Quality

The key features of ChargePoint® split valve technology ensure your process is not only running effectively but that you benefit from a low cost of ownership by, delivering solutions that maximise yield, reliability productivity and flexibility.

Secure Pressure Rated System

With the ability to charge/dispense under pressure or full vacuum, the ChargePoint® system does not rely on disc thickness for pressure rating. This means the disc cross section does not further impede powder flow and makes manual operation easier.

Efficient Cleaning and Maintenance

A range of devices are available for washing and steam cleaning the valve in place (WIP / SIP). ChargePoint® valves are designed with minimal parts, for quick disassembly and can also then be autoclaved for thorough cleaning.

Precision Machined Seats

Gives optimum operational performance and inter-changeability between Active and Passive units of the same size.

Metal-to-Metal Disc Seal

No need for additional o-rings or inflatable seals that can become damaged or provide a product trap.

Robust Fabrication

Machined from solid metal with no fragile pins or connections, ensuring long lifetime, trouble free performance.

Simple Operation

Manual operation is easy even with larger valve sizes. Valves can also be pneumatically operated and provided with a local operator control panel.

Safety Interlocks

Ensuring the Passive and Active valves cannot be opened when not docked together.

ChargePoint® split valve technology for safer and cleaner product transfers



- 🎯 Process your API's, ensuring the safety of the operating environment by maintaining the required OEL over extensive operating periods.
- 🎯 Protect your sensitive products with our solutions for clean product transfers.
- 🎯 Eliminate dust in the processing of your raw materials, reducing costs associated with downtime and cleaning.
- 🎯 Increase your product yield.
- 🎯 Improve your OEE (Overall Equipment Effectiveness).



Industry Applications

Pharmaceutical & Biopharmaceutical	R&D, Pilot and Production Scale Oral, Injectable and Inhalable Formulations, Generics
Food & Beverage	Dairy, Bakery, Tea, Coffee, Spices, Herbs, Flavours, Cereals, Cocoa, Fragrances, Colourants
Chemical/Fine Chemicals	Active Ingredients, Intermediates, Reagents
Consumer Goods	Cosmetics, Detergents
Metallurgical	Metal Powders, Batteries

Operational Principle

- Passive Body
- Active Body
- Product
- IBC
- Active/Passive Disc

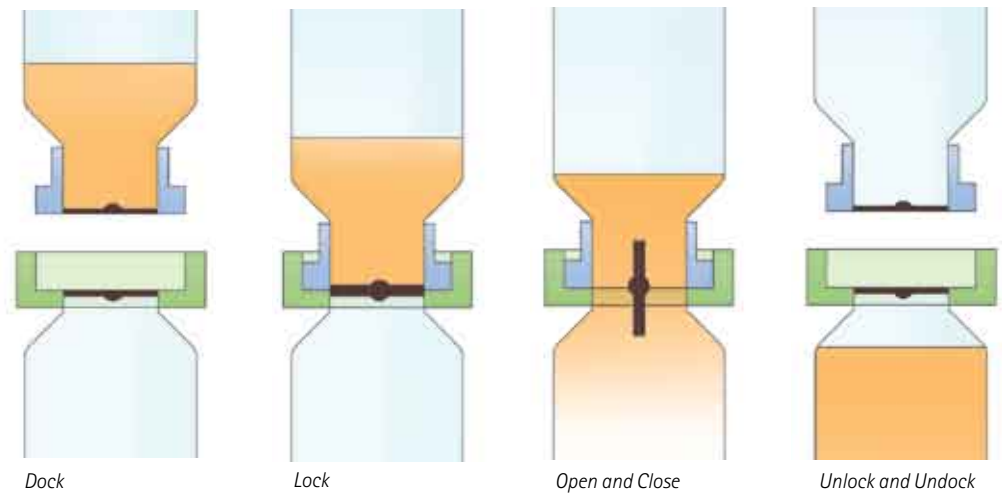

Dock

Lock

Open and Close

Unlock and Undock

ChargePoint®

The standard ChargePoint® offers entry level dust control and a containment performance of $<10\text{mcg}/\text{m}^3$ to ensure the safety of the operating environment.

The economic design permits simple installation and manual operation making it ideal as a retrofit for containment to existing, previously non-contained powder transfer processes.

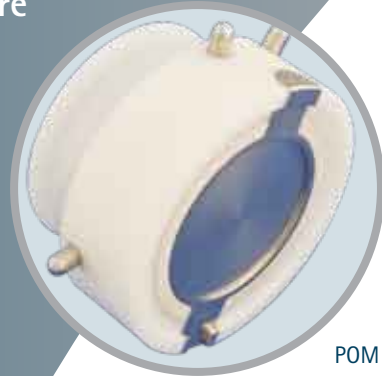

POM Passive

Passive unit options

A variety of material options are available for the Passive unit to meet product/solvent compatibility and manual handling requirements.

316L	
Alloy C22	
316L Lightweight design	Up to 25% less weight than 316L
POM	Up to 70% less weight than 316L



316L Passive



Contained milling

ChargePoint® with lightweight design Passive. Active with vibration isolation.

Pressure Rated System

A unique option for secure powder transfer under pressure or vacuum conditions.

- Secure transfers between pressurised vessels.
- Charging and running process under pressure.
- Maintain thin disc profile for uncompromised powder flow.
- Rated up to 6Bar and full vacuum.

Applications

Pressurised contained batch transfers. Connected IBC/containers can be pressurised with dry or wet purging.

Can be integrated into conventional vacuum transfer systems.

Steam sterilise in place through the open valve whilst maintaining pressure conditions.

Pressure Rated Sightglass offers visibility into process, utilising existing ChargePoint® installation.

Pressure Rated Sightglass

A Pressure Rated ChargePoint® can be installed and used for both product charging and as a viewing port once the charge has been completed.

This has a benefit in cases where there is no spare reactor nozzle. A Pressure Rated Sightglass offers visibility utilising the existing ChargePoint® installation.



Pressure Rated ChargePoint® with Pressure Rated Plug in place

Technical Overview

A pressure/vacuum seal is achieved with an o-ring between the body of the Passive or Plug and the body of the Active.

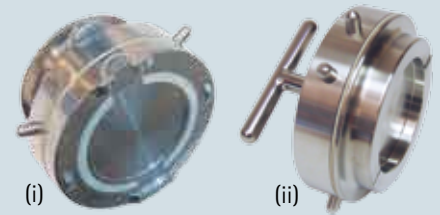

By adapting this method of pressure sealing, the disc design is not affected in terms of increasing disc thickness. As a result powder flow through the valve is not compromised.

The pressure system is not dependent on utilising the discs. When fitted with a suitable Passive (i) arrangement, the valve can be opened up to pressures of 6BarG or full vacuum. This is unique to ChargePoint Technology.

Alternatively, the valve can be simply isolated for pressure or vacuum with the use of a solid Pressure Rated Plug (ii), which also inhibits the Active from opening.

Pressure Rated ChargePoint® with Pressure Rated Sightglass



The standard ChargePoint® can be adapted for processes that require a higher level of containment performance.

This is achieved with either an Extraction Ring or the ChargePoint® EXCEL.

Extraction Ring System

An economic upgrade to high containment.

The Extraction Ring offers a containment performance of $<1\text{mcg}/\text{m}^3$ with the ability to adapt directly onto a standard ChargePoint® without any modifications.

This makes the Extraction Ring an economic upgrade to high containment as a retrofit to existing installations or as a mobile accessory in facilities with multiple ChargePoint® systems.

The extraction system can be provided in the form of a safe change HEPA filtered mobile skid which can be utilised at multiple stations.



Technical Overview

The Extraction Ring comprises of a circular plenum arrangement, which couples to the Active unit and is connected to an extraction source.

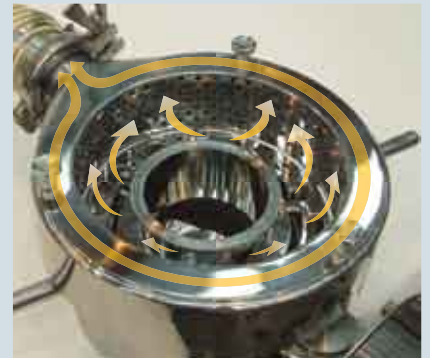

During docking, charging and undocking, the extraction is operated to ensure that any potential airborne particles are safely taken into the extracted air stream.

ChargePoint® EXCEL

Nanogram level containment performance.

This patented technology offers an advanced level of high containment performance to low nanogram levels. The design offers maximum operator protection in an compact, efficient split valve.

Optimise investment costs.

Remove the requirement for cleanrooms and PPE (Personal Protective Equipment) and future proof your process for higher OEL products.



ChargePoint® EXCEL used for reactor charging

Technical Overview

The valve varies from the standard ChargePoint® in that it incorporates purge and extract connections on the Active unit.

During the undocking process, an interlocked mechanism inhibits the Passive removal to a point where a gap is achieved between Active and Passive disc faces.

At this point the purge and extraction process is carried out, removing traces of particles that can potentially become airborne.

The ChargePoint® EXCEL is provided with an all-pneumatic control station, accommodating safe change HEPA filtration, pneumatic extraction and local operator control panel.

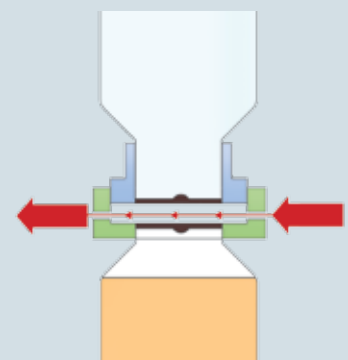

ChargePoint® DL

With the introduction of the innovative DiscLock™ (DL) range of valves from ChargePoint® Technology, the fast and secure transfer of larger quantities of powder, granular and semi-solid ingredients has just become a whole lot more efficient and economical.

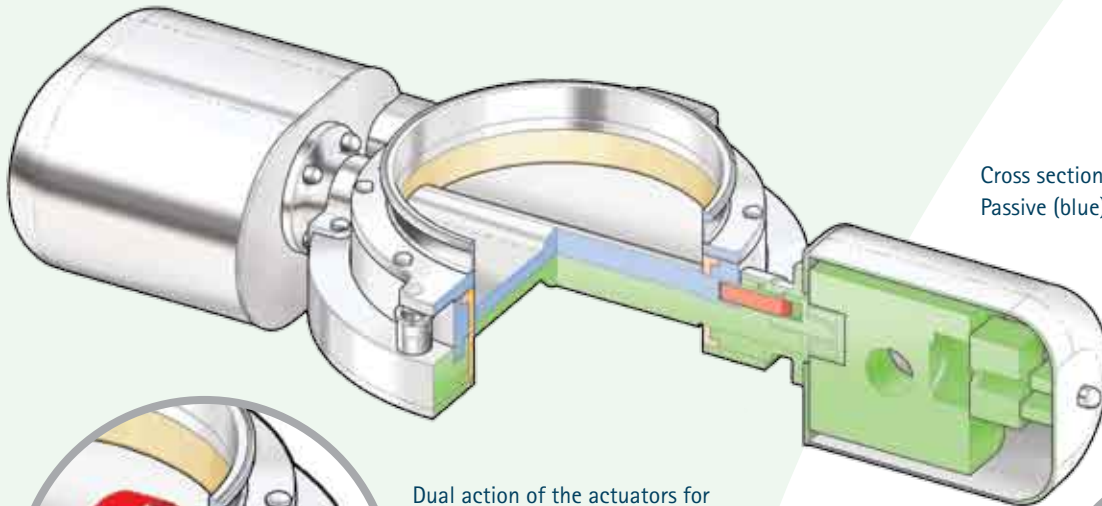

Cross section showing the Active (green), Passive (blue) and the DiscLock™ system (red).

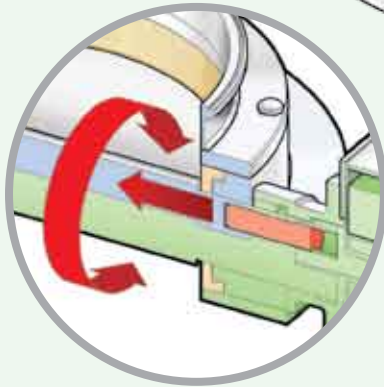

Dual action of the actuators for DiscLock™ and opening/closing of the valve



Fast, Secure Product Transfers

Our proven metal-to-metal disc sealing method eliminates the need for additional solid or inflatable seals. This avoids unnecessary parts that may become damaged or be subject to a loss of air pressure, both of which can affect the containment integrity of the valve.

The other key benefit of this design is that the disc profile is minimised ensuring more rapid transfer of the material – a key requirement for bulk material transfer.



Containment and Dust Control

Our DiscLock™ technology (patent pending) provides a means to directly lock the Passive and Active disc halves together to maintain the containment seal. This design ensures there is a much reduced risk of disc separation when forces are being exerted on the valve via IBC loading and offset mechanical forces.

As standard, the containment performance is between 1-10mcg/m³. This can be improved with the addition of optional extraction systems.

An Economic Solution

A further benefit of our DiscLock™ design is the dual action of the actuators. This feature reduces the weight, height and cost profiles of the valve.

Cleaning and Washing

The ChargePoint® DL valves are specifically designed for effective washing either in place or within a remote station with our WIP Passive or Wash Station Active.

TransferPoint™

The TransferPoint™ provides a technically superior yet cost effective solution for transferring material from one IBC to another.

 Transfer material from container to container using the same or **different** sizes of Active or Passive valves.

BridgeBreak™

The ChargePoint® BridgeBreak™ device can be fitted to new or existing systems to effectively prevent bridging or ratholing within the IBC / container during discharging.

Vibration of the BridgeBreak™ device ensures a constant, uniform material flow with the added benefit of preventing segregation.

Cleaning and Washing in Place

The ability to effectively clean or wash the product contact and sealing faces of the ChargePoint® valve in place is assured by the use of our specifically designed WIP or SIP devices.



WIP Passive

The WIP Passive mimics a standard Passive by locking into the Active unit. Incorporating a static sprayball coupled to a wash fluid source, the WIP Passive features an o-ring on the outer perimeter to create a liquid seal between the Active and Passive units. The wash fluid drains through the open valve to the process below.

- 🎯 Local cleaning of the Active unit inner product contact and sealing surfaces.
- 🎯 For use in the upright orientation.
- 🎯 316L or HPDE.

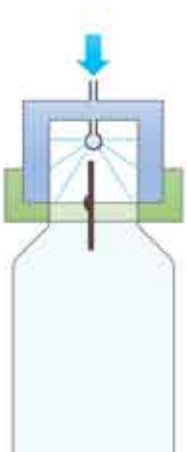

WIP Lance

The Sprayball and lance are contained within flexible PTFE bellows, connected on one side to a Passive unit and at the other end a stainless steel traversing platform, enabling the assembly to be moved up and down. As the lance assembly passes down through the valve, it washes the valve and disc faces and through the nozzle connection into the vessel.

- 🎯 Local cleaning of the ChargePoint® valve, vessel connection nozzle and even further into the process vessel itself.
- 🎯 Achieved via a dual Sprayball Lance linked to a single source CIP connection.

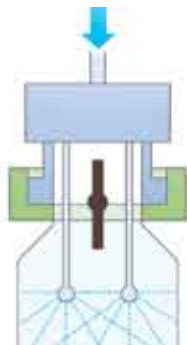

WIP Drain Passive

- 🎯 When the Active is installed in the inverted orientation, the WIP Passive drain features a fixed sprayball and also a drain point to allow the wash fluid to drain safely from the valve.
- 🎯 316L or HPDE.



Solutions for Clean Processing

The ChargePoint® range has been developed to accommodate aseptic conditions when required.

Level 1 – ChargePoint®

Sterilisation of ChargePoint® Active and Passive units.

This first method involves sterilising the ChargePoint® Active and Passive product contact and sealing surfaces prior to carrying out the charging of product through the valve.

There is a brief period prior to docking when the Active and Passive mating surfaces are exposed to the production environment.

This surface exposure has a varying effect dependent on room classification and needs to be assessed in line with the process specifics.

SIP Passive

The unique design of the Active half on the ChargePoint® allows an SIP Passive to be located within the Active enabling the disc to be opened.

A pressure seal is maintained by an o-ring seal on the outer perimeter of the SIP Passive. Steam is then introduced (in line with an appropriate approved procedure).

Vaporised Hydrogen Peroxide has also been used as an alternative decontamination process.



Sterilize the inner surfaces of the valve, disc and disc edges.



316L.

Level 2 – ChargePoint® BIO

Bio-decontamination.

This second level involves pre-sterilising the ChargePoint® Active and Passive as per level 1.

To ensure a satisfactory level of bio-decontamination of the Active and Passive mating surfaces that are momentarily exposed to the environment prior to docking, a further step is introduced which involves exposing these surfaces to VHP (Vaporised Hydrogen Peroxide) within a sealed void between the disc faces, prior to fully docking together and completing the product transfer.

ChargePoint® EXCEL

This additional step can be applied to both levels when both product and operator protection are a concern.

Once product transfer has been carried out under sterile conditions, the ChargePoint® EXCEL technology will perform a contained cleaning cycle to achieve a nanogram level of containment performance.

Applications

Single and multiple batch aseptic powder transfers.

Charging and discharging applications.



Options and Accessories

Automation

Three optional levels of automation can be provided with ChargePoint® valves to operate in hazardous or inaccessible areas or when the production scale does not permit manual handling.

	Raise and Lower	Locking Passive to Active	Valve open/close
Semi Actuated			●
Fully Actuated		●	●
PowerDock	●	●	●

Semi Actuated ChargePoint®

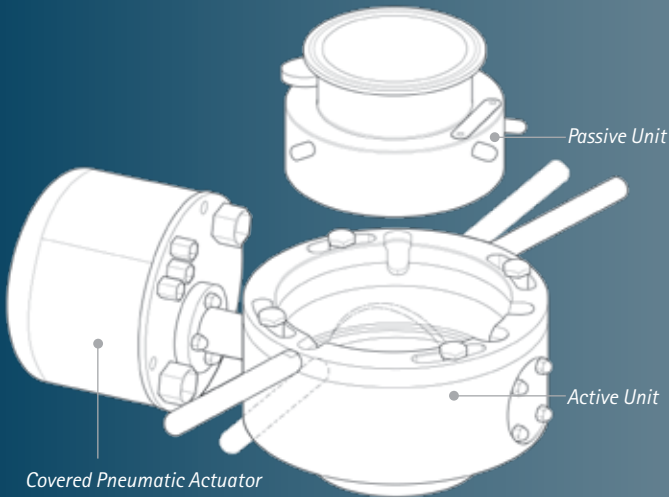

Fully Actuated ChargePoint®

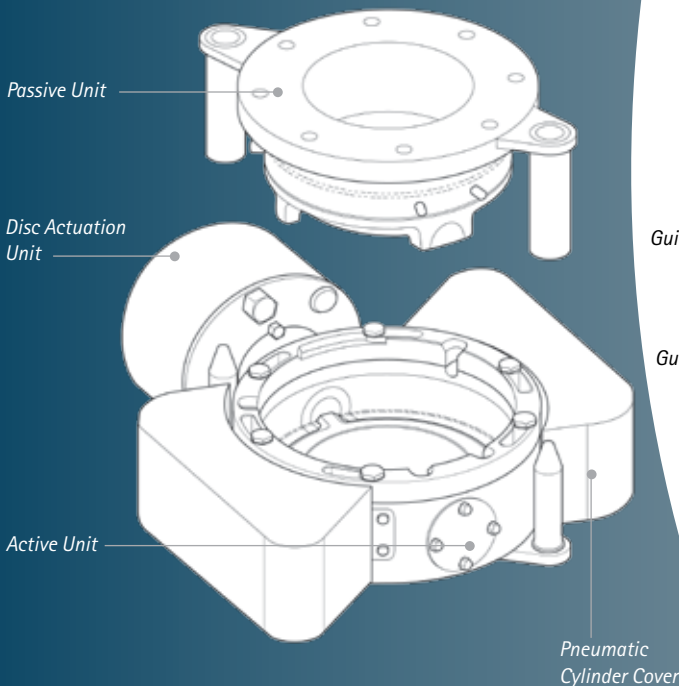

PowerDock™

The PowerDock™ system facilitates the automated raising and lowering of the Active when docking to a Passive. A unique bearing arrangement also corrects any mis-alignment between the process equipment for repeatable docking accuracy.



PowerDock™

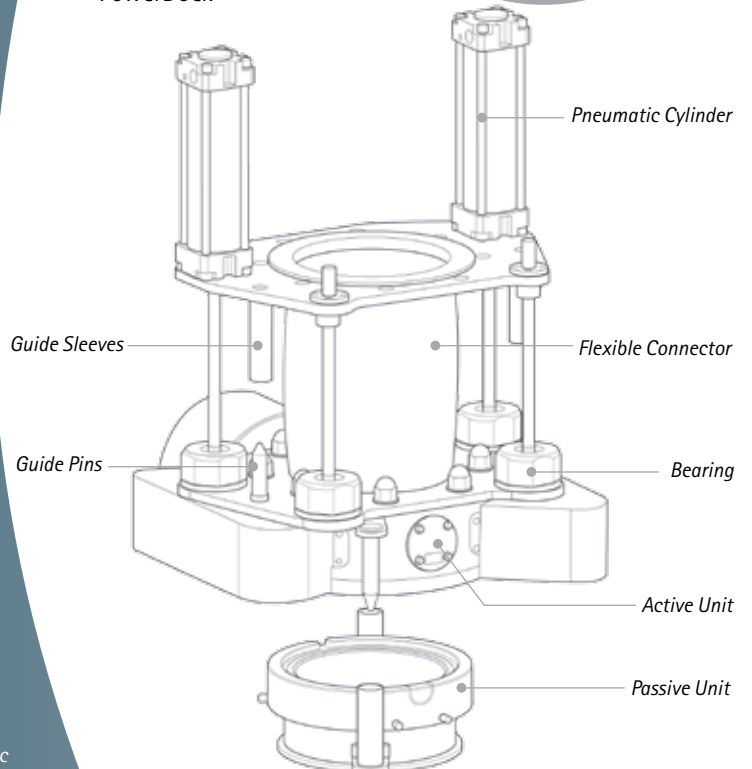

Docking Guidance

Robust pins and sleeves ensure correct alignment of the Active and Passive units in conjunction with the PowerDock™ system or lifting hoists.



Docking Compensator

A compensator absorbs the forces encountered during docking, removing the risk of damage to process equipment.



Sensors

Pneumatic or electric proximity detection sensors, combined with existing mechanical safety interlock features ensure the safe function of the ChargePoint® and integrated lifting equipment in fully automated, inaccessible or hazardous area operations.

The detection signal can be used in conjunction with a ChargePoint® or customer supplied control system providing an identification sequence which typically involves:

1. Positive identification Passive unit is correctly docked into Active.
2. This provides release mechanism to lock the Passive to the Active unit.
3. Further detection confirms this locking is complete.
4. This allows the valve disc to be opened.
5. Additional detection confirms the valve is open.



GMP Covers

GMP Plugs and Covers, manufactured in HDPE, help protect the valve and prevent the ingress of contamination whilst the valves are in transit or storage. The Passive cover can also be security tagged.



Containers

Containers are available in a variety of sizes and materials to suit specific process requirements.

ChargeBag™

- 🎯 Packed individually and sterilised within a sealed liner.
- 🎯 Simple polypropylene tri-clamp docking ring attaches to the ChargePoint Passive.
- 🎯 Clear, double ply LDPE materials of construction allow visual inspection and verification of complete product charge/discharge.
- 🎯 Flexible for physical manipulation of cohesive or poorly flowing powders.
- 🎯 Antistatic material properties ensure yield is maximised with each batch transfer.



ChargeBottle™

Lightweight translucent Polypropylene bottles to suit the ChargePoint® range are available in various capacities with Tri-clamp connections from 50mm (2") to 150mm (6").

Stainless steel containers are also available in a range of sizes.



Pressure Rated Containers

Pressure rated ChargeBottle™ can be supplied for pressure charging and flushing capability. The base of the vessel is profiled with a dome to minimize product hold-up and assists with the flushing of product out of the vessel.

Please contact us for more details and the full range of sizes and options available.



Bottle Handle Clamp

The stainless steel clamp is connected to a container for safer manual handling via the ergonomic hand grips. Clamping the band to a container is simply achieved by an over centre latch, which allows for easy installation and removal for transfer between multiple containers.



Bottle Hoists & Platforms

Simple mobile bottle hoists and specialised discharge stations, incorporating weigh platforms and pneumatic raise/lower docking arrangements can be provided to suit various discharging applications.



Vibratory Collar

Pneumatically powered, this removable vibratory clamp is fitted to containers to assist with discharge of powder product with inherent poor flow characteristics.

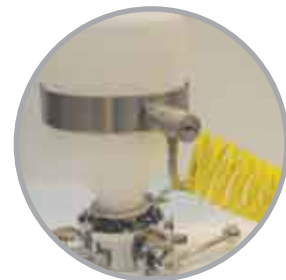

Bottle Wash Stations

Inverted WIP Lance assemblies can be utilised in conjunction with Bottle or IBC wash stations. The Lance can either be manually raised/lowered or pneumatically actuated, operated from a local operator control panel.

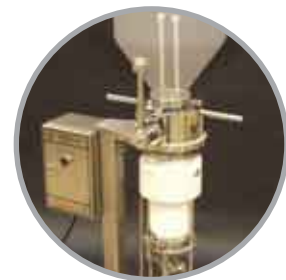

Specifications

		ChargePoint®	ChargePoint® EXCEL	ChargePoint® DL
Containment Performance		<10mcg/m ³	<1mcg/m ³	1-10 mcg/m ³
Size	50mm (2")	●		
	100mm (4")	●	●	
	150mm (6")	●	●	
	200mm (8")	●	●	●
	250mm (10")			●
	300mm (12")			●
Pressure Rating ¹		Up to 6Bar (87psi) ¹	Up to 6Bar (87psi) ¹	None
Product Contact Materials	316L	●	●	●
	Alloy C22	●	●	●
Seals	EPDM	●	●	●
	FKM	●	●	●
	FFKM	●	●	●
Connection Interface ²	Tri-clamp	●	●	Connection to suit IBC/container
	PN6	●	●	
	PN10	●	●	
	ANSI 150#	●	●	
Operation	Manual	●	●	
	Semi Actuated	●	●	
	Fully Actuated	●	●	●

¹ Pressure ratings vary upon the size and version of valve. Active is pressure rated when used in conjunction with a Pressure Rated Plug, Passive or Sightglass. Passive can only be pressure rated when coupled to a pressure rated Active or Pressure Rated Cover.

² Other connection interfaces are available upon request.



ChargePoint®

ChargePoint® EXCEL

High containment valves for cleaner, safer,
powder handling

International

80 Venture Point West
Evans Road
Liverpool L24 9PB
United Kingdom
T: +44 (0)151 728 4500
F: +44 (0)151 728 4501
E: sales@thechargepoint.com

Americas

211 Potters Drive
Bayville NJ 08721
United States
T: + 1 (732) 269 0606
F: + 1 (732) 269 0406
E: sales@thechargepoint.com

Find your local ChargePoint representative
online:

www.thechargepoint.com